



SECURITY SYSTEMS

Wireless Door Alarm System Installation and Operation Manual



SECURITY



ACCESS



CONTROL



VIDEO

www.ptisecurity.com

800.331.6224

114A3873 Rev D - July 2017



Wireless Door Alarm System



Thank you for purchasing the Wireless Door Alarm System. While every effort has been made to ensure the accuracy of the information in this document, PTI Security Systems assumes no liability for any inaccuracies contained herein. We reserve the right to change the information contained herein without notice.

NOTICE: To comply with FCC and or Industry Canada rules (IC), adjustment or modifications of this receiver and/or transmitter are prohibited, except for changing the code setting or replacing the battery. THERE ARE NO OTHER USER SERVICEABLE PARTS.

This device complies with part 15 of the FCC rules. Operation is subject to the following two conditions: (1) This device may not cause harmful interference, and (2) This device must accept any interference received including interference that may cause undesired operations.

© 2009-2017 PTI Security Systems. All Rights Reserved.

All rights reserved. No part of this publication may be reproduced, transmitted, transcribed, or translated into any language in any form, by any means, without written permission of PTI Security Systems.



This equipment generates, uses, and can radiate radio frequency energy and if not installed and used in accordance with the instruction manual, may cause interference to radio communications. It has been tested and found to comply with the limits for a Class A computing device pursuant to Subpart J of Part 15 of FCC rules, which are designed to provide reasonable protection against such interference when operated in a commercial environment. Operation of this equipment in a residential area is likely to cause interference in which case the user, at his/her own expense, will be required to take whatever measures may be required to correct the interference.



With the RS485 communication scheme, a keypad can be located as far as 4000 feet from the controller, therefore shielded twisted pair cable with ground wire is required for optimal operation. Additionally, larger gauge wire must be used the farther the device is from the controller,



Incorrect installation of electrical components can result in damage to electronics as well as personal injury.



Cross-wiring the AC power with the DC power will damage the electronics.



Cross-Wiring the Power wires with the Data wires will damage the electronics



Cross-wiring the positive and negative on the DC part of the system will damage the electronics.



Do NOT run low voltage system wires in the same conduit as high voltage wiring



The system will not operate properly if the voltage is below 12VDC. Extreme care should be taken when choosing a power supply voltage and current rating. Long distance runs may require a remote power supply to be installed in line with an RB5 relay to ensure proper operation.



Warning: The User should follow all installation, operation, and maintenance instructions. The User is strongly advised to conduct product and systems tests at least once each week. Changes in environmental conditions, electric or electronic disruptions and tampering may cause the product to not perform as expected.



PTI Security Systems warrants its Product to the User. The User is responsible for exercising all due prudence and taking necessary precautions for the safety and protection of lives and property wherever PTI Security Systems products are installed. PTI Security Systems does not authorize the use of its products in applications affecting life safety.

Contents

Introduction	1
System Requirements	1
Installing Wireless Door Alarm Transmitters.....	2
Tools & Equipment	3
Selecting the Mounting Location	4
Mounting the Door Magnet	4
Mounting Door Transmitters.....	5
Roll Up Doors	6
Swing Doors	13
Testing the Transmitter Location.....	18
Installing the Wireless Multiplexer	23
Locating the Wireless Multiplexer	24
Connecting the Wireless Multiplexer	25
Operating the Wireless Multiplexer	30
Displaying the Multiplexer Address and ID	31
Setting the Operating Parameters via 'Setup Mode' ..	32
Relay 2 Function	36
Register Transmitters	38
Setting Up the Controller	44
Reported Events	46
Wireless Repeaters	51
How Many Repeaters are Needed?.....	51
Repeater Location	52
Installing the Repeaters	53
Testing the Installation.....	55
System Maintenance & Troubleshooting.....	59
System Maintenance	59
Periodic Visual Inspection.....	59
Monitor the Door Activity Reports.....	59
Battery Replacement	60
Troubleshooting Door Alarms	71
Warranty & Disclaimer	74

Technical Specifications

Input Power:

Voltage:	12 - 18 VDC / VAC
Current	300mA maximum

Relay Specifications:

Maximum Switching Voltage*:	30 VAC / 24VDC
Maximum Switching Current*:	1A (NO / NC)
* Resistive Load	

Environmental:

Ambient Temperature:	-40°C to +85°C (-40°F to 185°F)
Ambient Humidity:	0 to 85% non-condensing

NOTE: not intended for outdoor installation

Introduction

Most conventional door alarm systems have a door switch hardwired to the alarm system requiring a lot of wires run throughout the facility. If running wires to every door is not feasible, a wireless door alarm system is the solution.

PTI's wireless door alarm system has a battery-powered transmitter installed at each door, a wireless multiplexer, and wireless receiver connected to the multiplexer. On a typical installation transmitters have a range of around 400 feet, however the actual range will vary based on site conditions. On a large site, wireless repeaters should be installed to boost the signal from the transmitters and increase the signal range.

System Requirements

These items require a properly installed and configured control system. The wireless multiplexer and receiver will only work properly when installed and interfaced to the access control system. The firmware revision on the controller must be 4.10 or newer for correct operation of all features.

The recommended connection to the wireless multiplexer from the controller is through 18 AWG, 4-conductor shielded wire. This wire must be run from the nearest device to the multiplexer.

The wireless multiplexer requires 12 VDC power at 250 mA. Power is supplied by the power supply for the controller. Make sure the power supply is capable of handling the necessary load when the multiplexer is added.

The system will not operate properly if the voltage is below 12VDC. Extreme care should be taken when choosing a power supply voltage and current rating. Long distance runs may require a remote power supply to be installed in line with an RB5 relay to ensure proper operation.

Installing Wireless Door Alarm Transmitters

The transmitter is designed for swing or roll-up doors. It can be mounted vertically or horizontally to accommodate different door and header types.

The door transmitter assembly consists of the transmitter box, a mounting plate, the door magnet, and the assembly hardware. "Drawing 1: Wireless door Alarm transmitter" shows the door transmitter components.

The mounting plate simplifies installation and maintenance of the door transmitters. If a transmitter needs to be removed, the mounting plate enables it to be reattached in the same position.

Drawing 1: Wireless door Alarm transmitter

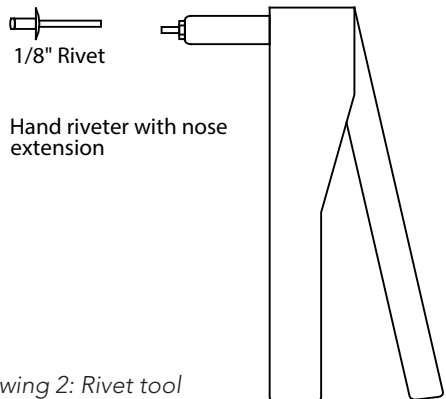
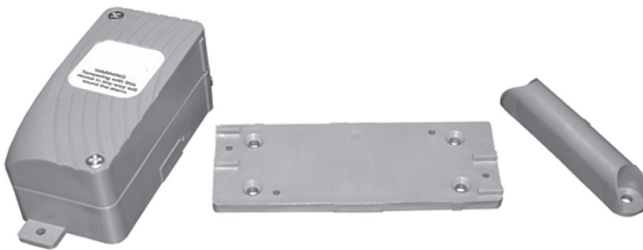





Drawing 2: Rivet tool

Tools & Equipment

The following list of tools and equipment is needed for successful installation of the transmitter assembly. Before beginning the installation, gather the following required tools and equipment. Most of these tools are available from PTI Security Systems.

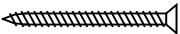
- PL Premium® Construction Adhesive
- Screw drivers (battery-powered recommended)
- Caulking Applicator Gun (standard tube size)
- Drill with Bits
- Concrete Drill Bits (depending on building construction)
- Transmitter Mounting Hardware Kit (See "Drawing 3: Mounting hardware kit")
- Pop Rivet Tool (See "Drawing 2: Rivet tool" on page 3)
The rivet tool has a special extension on the nose piece that allows it to align properly with the magnet mounting holes
- Pop Rivets for Magnet Mounting (See "Drawing 2: Rivet tool")
- Transmitter alignment tool

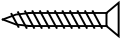
Drawing 3: Mounting hardware kit

- | | | |
|---|---|--|
| <p>① #6 × 1-1/2" FH Sheet metal screw.</p> |  | <p>(For transmitter lid)</p> |
| <p>② 6-32 × 3/8" PH Thread cutting screw.</p> |  | <p>(For fastening transmitter to mounting plate)</p> |
| <p>#8 Plastic screw anchor - use 0.250" drill for pilot hole.</p> |  | <p>(For concrete mounting)</p> |
| <p>③A #8 × 1" FH Sheet metal screw - use 0.116" (#32) drill for pilot hole.</p> |  | |
| <p>③B #8 × 1/2" FH Sheet metal screw - use 0.116" (#32) drill for pilot hole.</p> |  | <p>(For sheet metal mounting)</p> |

Selecting the Mounting Location

How and where door transmitters are mounted is critical to reliable operation of the alarm system. The mounting location must be close enough to the door to ensure proper operation of the magnetic contacts but not vulnerable to damage from door travel or traffic passing through the door.

The location must have clear sight to send a radio signal to the nearest transmitter. Optimal positioning depends on the type of door at the location.

Mounting the Door Magnet

Mount the magnet first before any other transmitter components. Read through the sections on positioning and mounting the magnet, transmitter, and mounting plate before permanently attaching any parts. Pay attention to the section on the mounting plate and its use as a spacer.

Mount the magnet to the door. The magnet must be attached to the door with PL Premium® adhesive and rivets or screws.

On thin metal doors (such as roll up doors), attach the magnet with a rivet tool using the rivets supplied by PTI Security Systems. The recommended method is to attach the magnet to the door with the PL Premium® adhesive, quickly drill the holes and install the rivets before the adhesive sets .

On some doors it may not be feasible to use rivets to attach the magnet. In these cases, attach the magnets with screws appropriate for the mounting surface.

NOTE: DO NOT allow the PL Premium® adhesive to bleed over the mounting hole as it could potentially cause damage to the drill bit when drilling the hole.

When installing the transmitter on the door jamb on a roll up or similar door, the center of the magnet should align roughly with the center of the alignment mark on the transmitter box lid. Because a magnet may need to be raised away from the door jamb, the transmitter mounting plates are designed to stack. This feature allows the installer to compensate for the increased gap and additional mounting plates are available from PTI.

Mounting Door Transmitters

The door type where the transmitter will be installed determines the correct mounting procedure to use:

NOTE: To ensure an easier installation, PTI recommends that transmitters are registered with the wireless multiplexer before attaching them to the mounting plates.

If the system was shipped complete by PTI Security Systems, the transmitters may have been registered to the multiplexer at the factory. If so, they will have a number on the transmitter housing that is the channel number assigned in the multiplexer.

Roll Up Doors

For this type of door, mount the transmitter in a location high enough off the ground to reduce the chance of physical damage, and close enough to the door for the magnet to work. PTI recommends mounting the transmitter on the facing of the door frame on the side of the door opposite the hasp.

Some roll up doors are equipped with a foot plate at the bottom of the door that has to roll past the transmitter as the door opens; the foot plate must clear the transmitter. If the door is equipped with a foot plate on each side, the transmitter can be mounted on the header of the door.

Take care when selecting a location; over time, many roll up doors move away from their tracks, and the door frame at the top of the door. This movement can create a gap too large for the magnet to work. Additionally, there must be very little movement when the door is latched, from wind or other vibration. Such movement generates an alarm.

The position of the magnet determines the mounting location for the transmitter. The magnet must be mounted in the trough of the door corrugation so that it will roll up without putting stress on the door mechanism or the magnet.

Position the magnet with the smallest possible gap between the magnet and the transmitter box. The transmitter box should be as close to the magnet as possible. **At no time should the magnet be more than ½" from the transmitter box after installation.** Use the alignment marks on the transmitter box to position the box and magnet.

Remember that roll up doors can move due to wind or other causes. Wear on the track and flexure from opening and closing the doors repeatedly will add to the door movement. Set the gap between

the magnet and the transmitter very carefully during installation to allow for this.

See page 9 and page 11 for detailed roll up door installation instructions.

Door Jamb Mounting Instructions

If placing the wireless box on the door jamb interferes with the travel of the toe plate and/or the door handle, use the Door Header Mounting Instructions instead on page 11

- 1 Apply PL Premium® construction adhesive to the back of the magnet. Align the center of the magnet with the narrow mark on the side of the mounting plate facing the door and rivet the magnet to the door no more than ½ inch away from the mounting plate. See page 5 for more information.
- 2 Apply PL Premium® construction adhesive to the back of the mounting plate and use two wall anchors and two #8 x 1" flat head screws to fasten the mounting plate.
- 3 Position the box bottom with the magnet alignment mark facing toward the door and fasten the wireless box bottom to the mounting plate using two 6-32 x 3/8" pan head screws.
- 4 Place the PC board in the box bottom and hold in place until the box cover is in place.
- 5 Fasten the box cover to the box bottom using two #6 x 1-½" flat head screws.

Application Note: Always use PL Premium® adhesive on the magnet and the mounting plate. The box assembly should be mounted as high as possible on the jamb to prevent damage

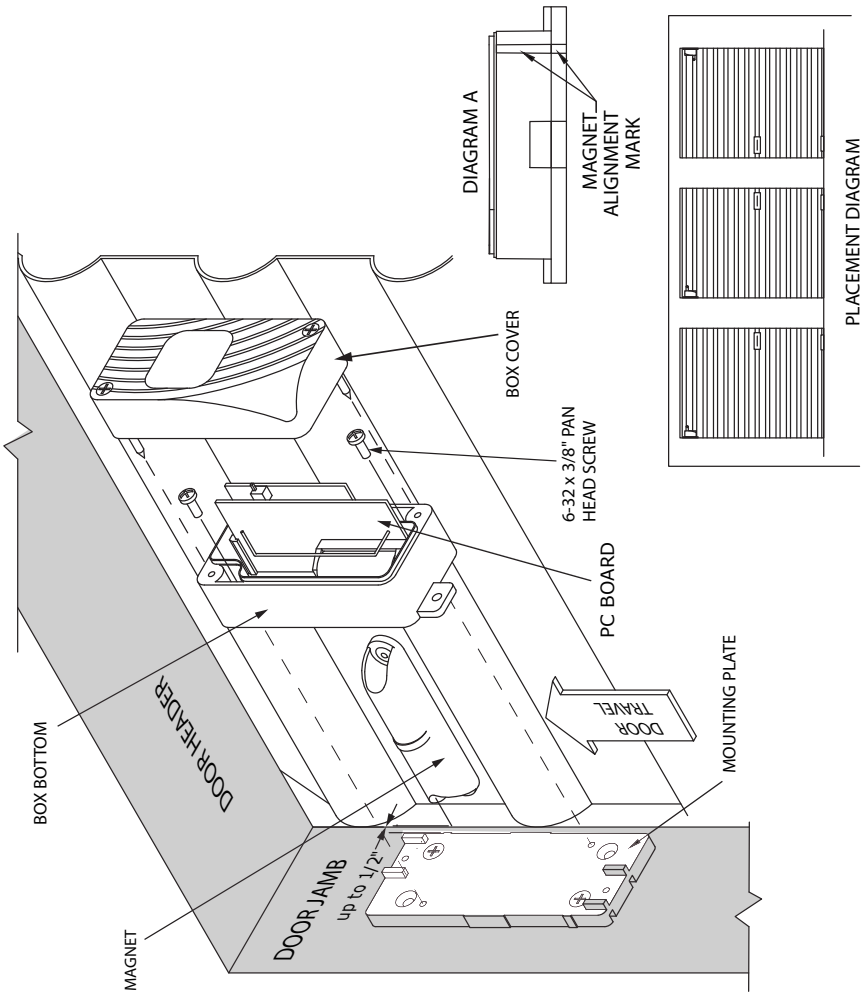

Drawing 4: Overhead Door Jamb Mounting

Door Header Mounting Instructions

Use this method if a door jamb mount not possible

- 1 Apply PL Premium® construction adhesive to the back of the magnet. Align the center of the magnet with the narrow mark on the side of the mounting plate facing the door and rivet the magnet to the door no more than ½ inch away from the mounting plate with two screws (type of screw used to be determined by door type). See page 5 for more information.
- 2 Apply PL Premium® construction adhesive to the back of the mounting plate and use two wall anchors and two #8 x 1" flat head screws to fasten mounting plate.
- 3 **Note: Place the box and magnet out of the travel path of the toe plate and/or the door handle.**
- 4 Position the box bottom with the magnet alignment mark facing toward the door and fasten the wireless box bottom to the mounting plate using two 6-32 x 3/8" pan head screws.
- 5 Place the PC board in the box bottom and hold in place until the box cover is in place.
- 6 Fasten the box cover to the box bottom using two #6 x 1-½" flat head screws.

Application Note: Always use PL Premium® adhesive on the magnet and the mounting plate. The box assembly should be mounted as high as possible on the jamb to prevent damage.

Drawing 5: Door Header Mounting

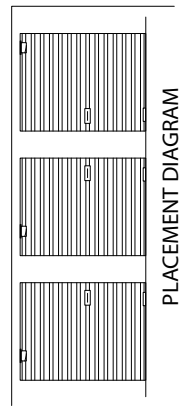
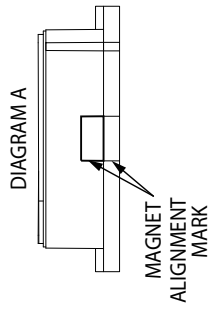
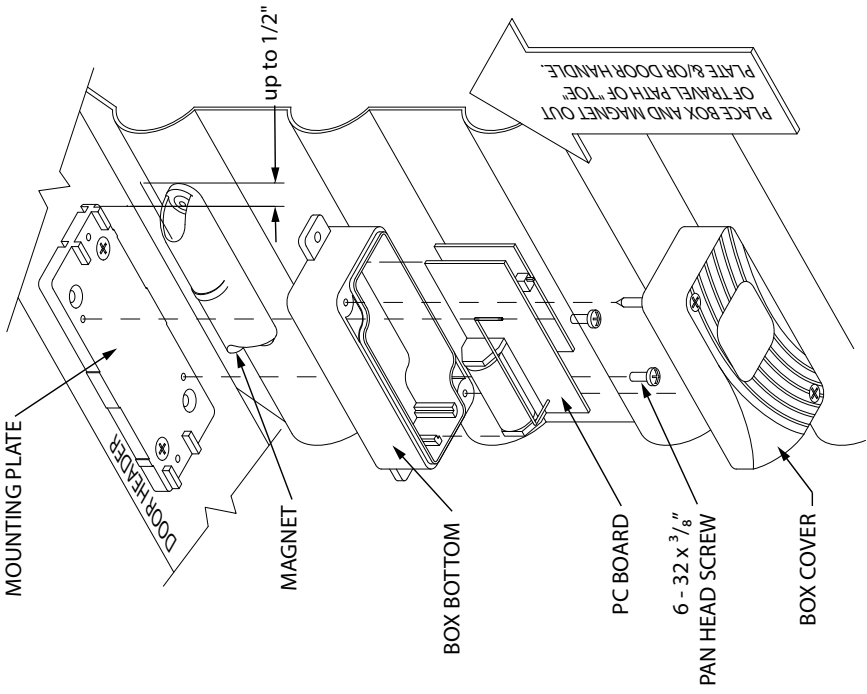

Swing Doors

On swing doors, the transmitter should be mounted in a location high on the door, out of the way of the door swing, and out of the path of doorway traffic.

The transmitter should be installed on the hasp side of the door on the jamb, or the header. See pages page 15 and page 16 for detailed swing door mounting instructions.

Position the magnet with the smallest possible gap between the magnet and the transmitter box. The transmitter box should be as close to the magnet as possible.

At no time should the magnet be more than ½" from the transmitter box after installation.

Use the alignment marks on the transmitter box to position the box and magnet.

Remember that swing doors can move due to wind or other causes. If there is too much movement on the latch side of the door, place the transmitter and magnet towards the the center of the door to reduce the chance of false alarms.

In some cases, there may not be enough room on the door jamb, or header, for the transmitter box. In these situations, mount the transmitter on the door and mount the magnet on the jamb, or header. However, this is not usually recommended due to the greater risk of damage to the transmitter from door movement.

Metal Swing/Slide Door Header Mounting Instructions

- 1 Apply PL Premium® construction adhesive to the back of the magnet. Align the center of the magnet with the narrow mark on the side of the mounting plate facing the door and rivet the magnet to the door no more than ½ inch away from the mounting plate with two screws (type of screw used to be determined by door type). See page 5 for more information.
- 2 Apply PL Premium® construction adhesive to the back of the mounting plate and use two wall anchors and two #8 x 1" flat head screws to fasten mounting plate.
- 3 Position the box bottom with the alignment marks facing toward the door and fasten the wireless box bottom to the mounting plate using two 6-32 x 3/8" pan head screws.
- 4 Place the PC board in the box bottom and hold in place until the box cover is in place (See Drawing 6 on page 16 for cover positioning).
- 5 Fasten the box cover to the box bottom using two #6 x 1-½" flat head screws.

APPLICATION NOTE: Always use PL Premium® adhesive on both magnet and mounting plate. Box assembly should be mounted in place on header to prevent damage.

Drawing 6: Metal
Swing/Slide Door
Header Mounting

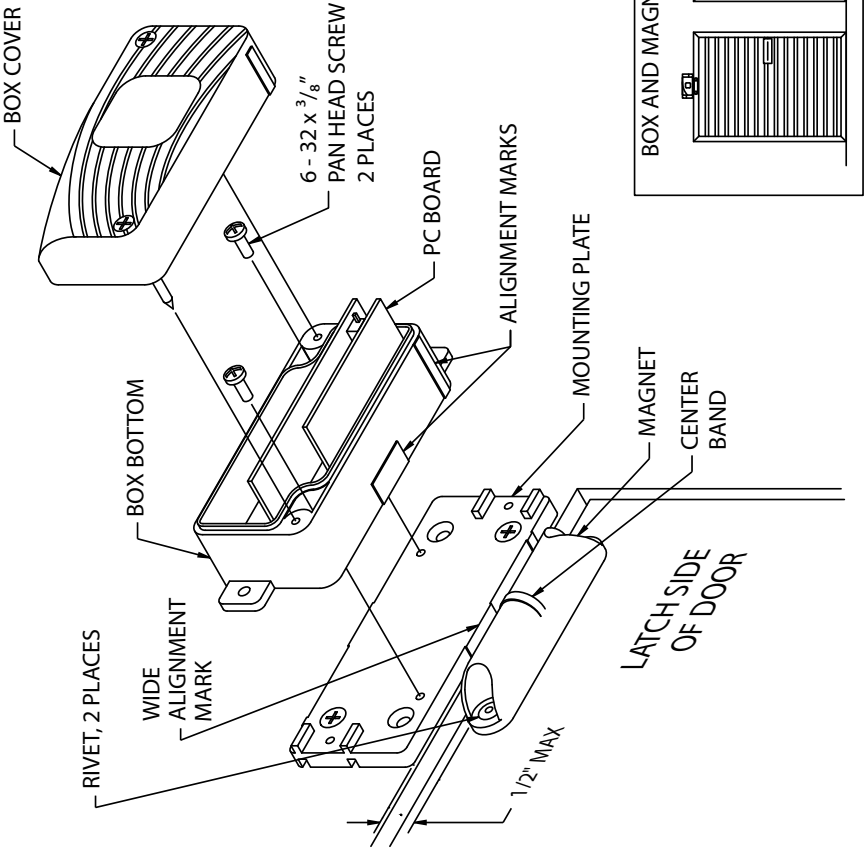

Hollow Core Swing Door Header Mounting Instructions

- 1 Apply PL Premium® construction adhesive to the back of the magnet. Align the center of the magnet with the narrow mark on the side of the mounting plate facing the door and rivet the magnet to the door no more than ½ inch away from the mounting plate with two screws (type of screw used to be determined by door type). See page 5 for more information.
- 2 Apply PL Premium® construction adhesive to the back of the mounting plate and use two wall anchors and two #8 x 1" flat head screws to fasten mounting plate.
- 3 Position the box bottom with the alignment marks facing toward the door and fasten the wireless box bottom to the mounting plate using two 6-32 x 3/8" pan head screws.
- 4 Place the PC board in the box bottom and hold in place until the box cover is in place (See Drawing 7 on page 18 for cover positioning).
- 5 Fasten the box cover to the box bottom using two #6 x 1-½" flat head screws.

APPLICATION NOTE: Always use PL Premium® adhesive on both magnet and mounting plate. Box assembly should be mounted in place on header to prevent damage.

Drawing 7: Hollow Core
Swing Door Header
Mounting

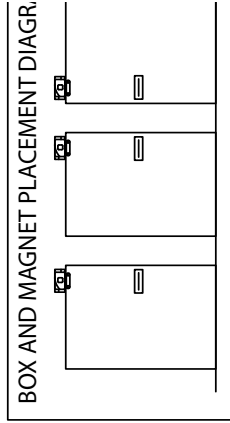
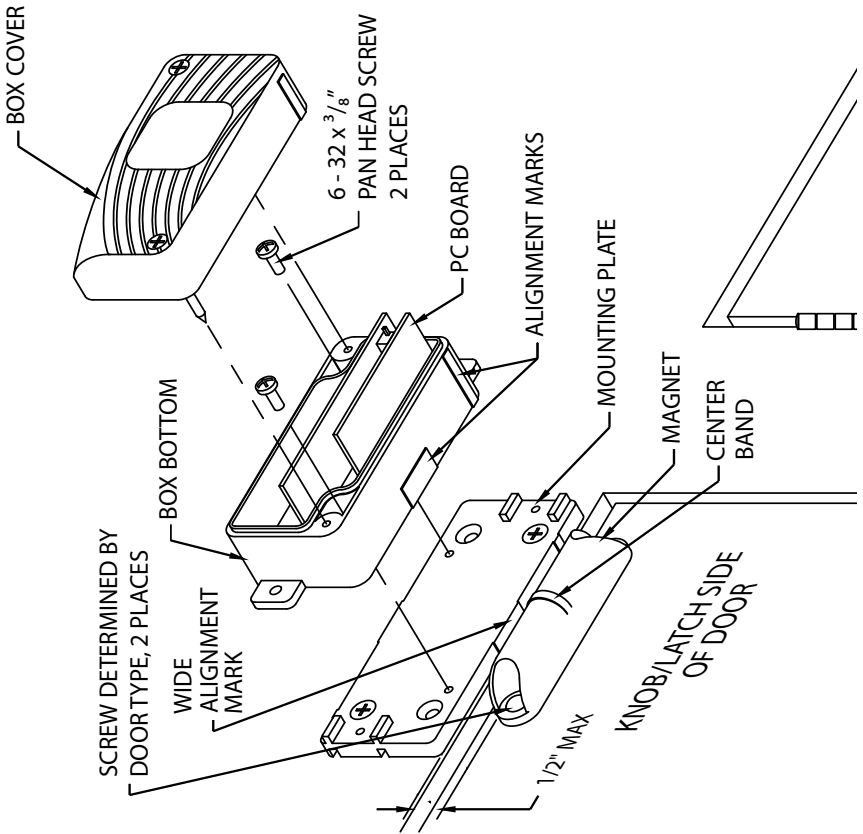

Testing the Transmitter Location

To help with installation, PTI Security Systems provides a transmitter alignment tool with every wireless headend. This tool helps the installer determine the alignment of the transmitter box and the magnet.

The tool has an LED that indicates when the door is reporting closed. When the door is closed and the transmitter is properly positioned, **the LED on the transmitter alignment tool will be ON.**

If the LED is not on when the door is closed, the magnet and transmitter are not properly positioned. The magnet may be too far from the transmitter box or out of alignment; adjust the position of the transmitter plate until the LED on the alignment tool turns ON. Note that the tool is only a test unit only and not a transmitter.

When the plate location has been determined, latch the door and then push, pull, tug, and move the door to make sure that the door movements will not trigger a false alarm.

Securing the Transmitter Mounting Plate

PTI recommends using mounting plates whenever possible.

- 1 Once the transmitter box is sited, install the mounting plate in that location. A hardware kit is provided for attaching the mounting plate to different surfaces.
- 2 The mounting plate must be attached using PL Premium® adhesive and at least two mounting screws, installed in opposite corners of the plate. This provides maximum strength and resistance to flexure.

- 3 PL Premium® adhesive must be applied to the area of the mounting plate that comes into contact with the mounting surface.

In some cases (usually roll up doors) the construction of the door frame may require that the mounting plate extend beyond or hangs over the mounting surface.

If this setup is required, use two mounting holes on one side of the plate. "Drawing 8: Mounting plate positioning" is a guide for affixing the mounting plate.

Drawing 8: Mounting plate positioning

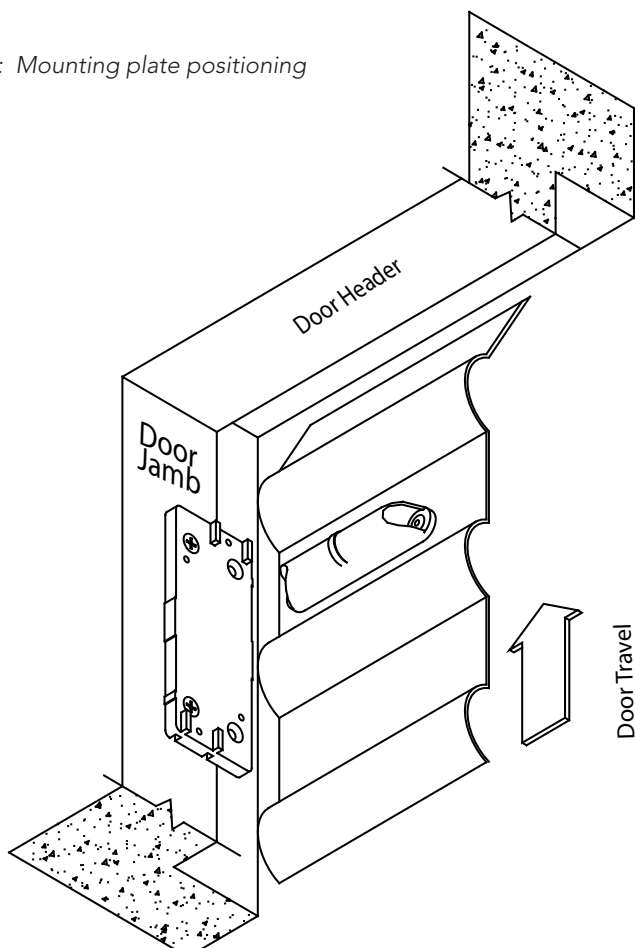

Attaching the Transmitter to the Mounting Plate

- 1 Transmitter boxes have mounting holes, accessible when the lid is removed. PTI recommends attaching the transmitter to the mounting plate using these holes as they provides increased security.
- 2 Whenever the lid is removed from a transmitter box, the transmitter sends a tamper alarm. If the transmitter is attached using the internal mounting holes, the lid cannot be removed from the base without sounding the tamper alarm.
- 3 In addition, each transmitter box is equipped with mounting tabs protruding from each end of the box. Only use these tabs if the transmitter is mounted in a secure area, such as inside a locked door.
- 4 Note: PTI does not recommend locating transmitters inside locked units where they are not accessible for regular maintenance.
- 5 Remove the cover on the transmitter box.
- 6 Position the transmitter on the mounting plate and attach it to the plate using the screws provided in the mounting hardware kit.
- 7 Check the battery on the transmitter board to make certain it is seated in the battery holder. Reinstall the cover on the transmitter box.

Do NOT use adhesive to attach the transmitter the mounting plate

Resetting the Transmitter

Each transmitter is equipped with a reset switch that must be pressed after changing the battery, or when registering the transmitter with the multiplexer. See “Drawing 9: Reset switch location” on page 22. If the battery is removed from (or loose in) the holder, press the reset switch after reseating the battery.

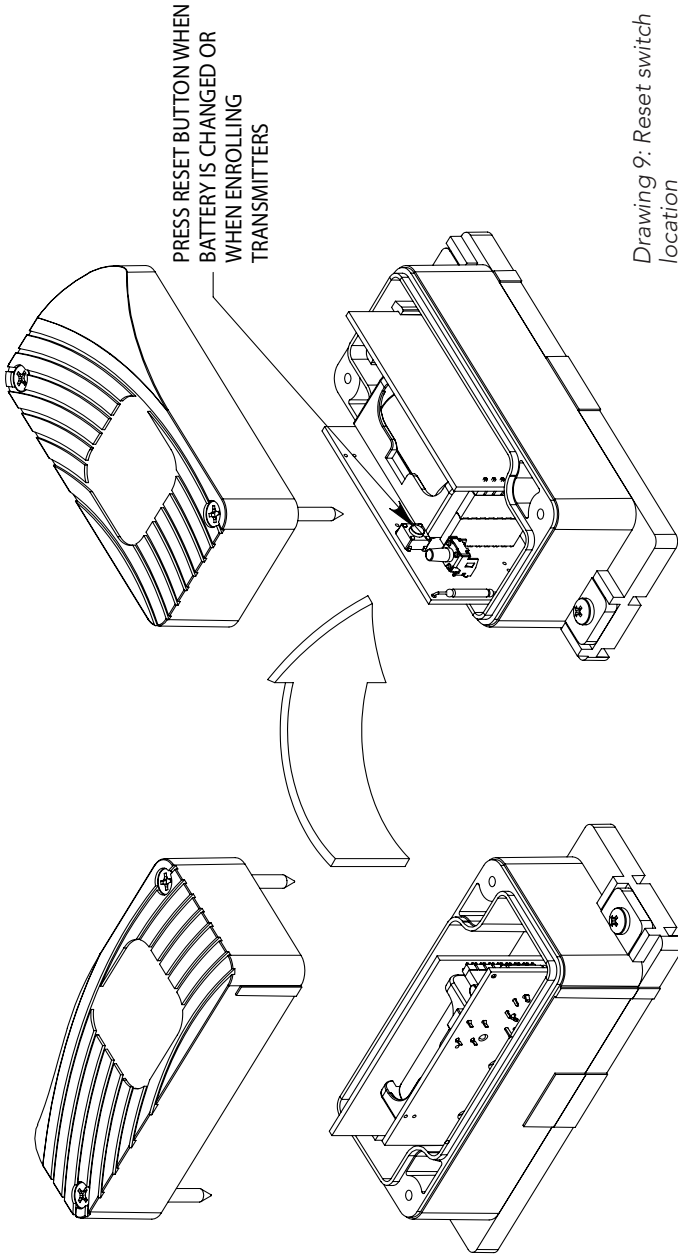

Drawing 9: Reset switch location

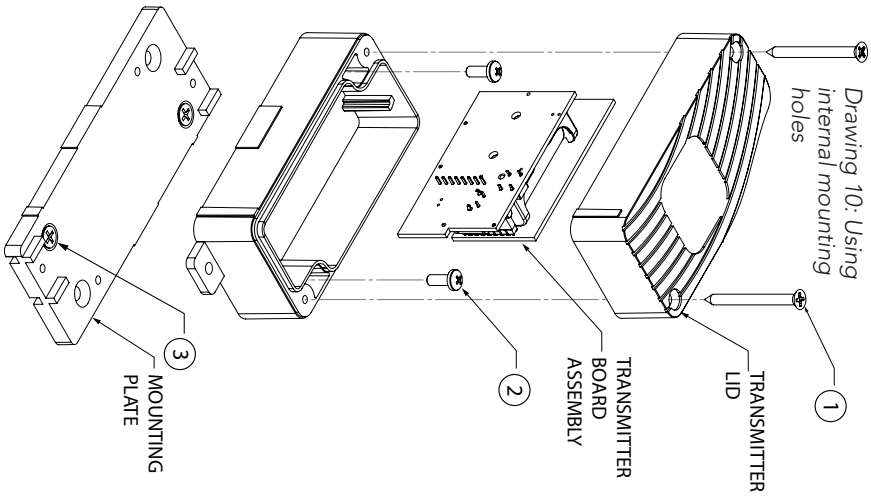

Drawing 10: Using internal mounting holes

“Drawing 10: Using internal mounting holes” shows the mounting of the transmitter using the internal mounting holes. The reference numbers shown in the drawing refer to the components in the mounting hardware kit.

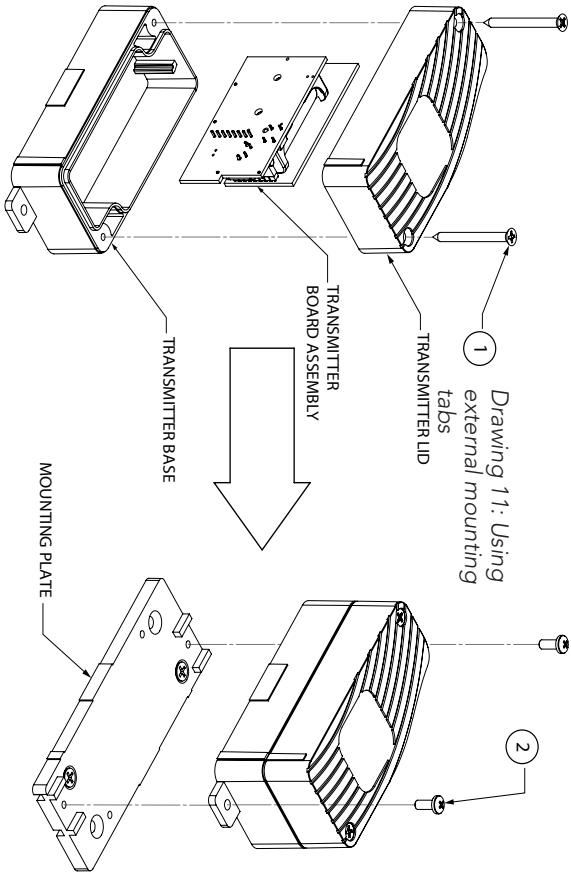

Drawing 11: Using external mounting tabs

“Drawing 11: Using external mounting tabs” shows the mounting of the transmitter using the external mounting tabs. The reference numbers shown in the drawing refer to the components in the mounting hardware kit.

Installing the Wireless Multiplexer

The wireless multiplexer is used to interface wireless transmitters to the access control system; a wireless receiver is also connected to the wireless multiplexer. The receiver picks up signals from transmitters and relays them to the multiplexer. The multiplexer then interprets these signals and determines the state of each transmitter. The configuration is shown in "Wireless multiplexer system" on page 24

Drawing 12: Wireless multiplexer system

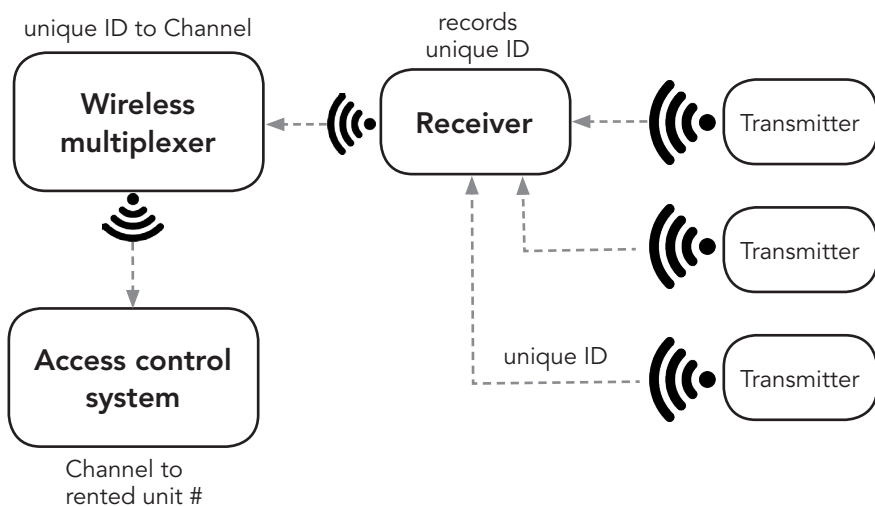

Each transmitter has a unique ID number that it transmits. The wireless receiver records this ID, and the wireless multiplexer associates this ID with a channel. Finally, the StorLogix software associates the channel number to a unit.

The wireless multiplexer and receiver run from 12 VDC and draw 250 mA of current. The transmitters use 900 MHz, spread spectrum, frequency hopping.

In perfect line of sight conditions, the transmitters have a range of 1000'. The typical range in less than ideal conditions is closer to 400'. The transmitters use CR123A, 3 V lithium batteries, giving them a battery life between 2-5 years.

There are two different generations of PTI wireless door alarms. The FA system is the older generation, and is not compatible with the newer system, the EchoStream system. You cannot mix the two different styles. When ordering replacement transmitters, make sure you know which type the site is using.

**Do not combine the FA door alarms with the EchoStream system. They are not compatible.
Make sure you know which type the site uses.**

Locating the Wireless Multiplexer

The wireless multiplexer must be installed in a secure indoor location, accessible for system programming and maintenance. Do not install where users can access the unit. The multiplexer should be installed in an office where general access to the unit is controlled and within 100 feet of the wireless receiver

Locating the Receiver

**The receiver must be installed in a secure, indoor, accessible location.
DO NOT mount the receiver high up in the building.**

It is good practice to mount the receiver close to the multiplexer it is connected to because every time a device is added to the programming, a button must be pressed inside the receiver.

If possible, keep the receiver away from large metal objects. DO NOT install the receiver on a metal surface they impair the performance of the receiver.

If there is a concern about signals reaching the receiver, a repeater can be placed high up and close to the receiver, and the signals can route through it if needed. The repeater does not have to be accessed for programming and therefore can be placed anywhere.

Connecting the Wireless Multiplexer

These instructions are for the installation of a wireless door alarm multiplexer in connection with an access control system. The multiplexer provides power for the receiver through a three-conductor cable. See "Drawing 15: Wireless multiplexer wiring" on page 25.

- 1 Place the multiplexer against the wall and mark the wall through the four mounting holes on the rear of the housing using a pencil.

- 2 Run 18 AWG 4-conductor shielded wire, in conduit, into the multiplexer housing through one of three conduit knockouts in the back of the box. These are double knockouts which allow room for $\frac{3}{4}$ inch or 1 inch conduit with compression fittings. If a larger size conduit is needed, the installer must drill the correct size hole in the housing in the bottom or lower back of the housing.

- 3 Pull the necessary wires through the wire hole on the back of the housing. Allow an extra 1 foot of wire to remain inside the housing. The wireless mux should have the following wires:
 - 1 of 18 AWG, 4-conductor, shielded cable coming in from the controller or from the previous AI device in line.
 - 1 of 18 AWG, 4-conductor, shielded cable going out to the next AI device in line (if there is another AI device down the line).
 - 1 of earth ground wire
 - 1 wire running to the receiver mounted nearby.

- 4 Mount the multiplexer against the wall using the four mounting holes. Use a torpedo level to verify that the housing will be mounted level, then mount the box to the wall using the appropriate anchors for the mounting surface.

- 5 Mount the receiver close to the multiplexer, using the mounting holes located on the unit. **The receiver wire connecting the two must not be over 50 feet long.**

- 6 Strip back the outer insulation and shield foil from both of the 18 AWG, 4-conductor, shielded cables (coming from the controller or previous AI device in line and going out to the next AI device in line), being careful not to cut the bare shield wire. Strip ¼ inch of insulation off the end of each of the individual colored conductor wires.

- 7 Remove the terminal block **P1** from the keypad circuit board by sliding it up and off. The terminal block may be somewhat difficult to remove as it is screwed on tightly. If the block is tight, rock it slightly back and forth while lifting away from the board.

- 8 Insert the **red** wire into **terminal slot 1** on the first terminal block (**P1**). Ensure the wire is seated all the way inside the slot. Use a flathead precision screwdriver to tighten down the terminal screw. If there is an incoming and outgoing wire, there will be two red wires. Insert both into **terminal slot 1** on **P1** and continue.

- 9 Verify that the terminal slot has tightened down on the copper wire and not on the rubber insulation. There should be no copper wire showing outside of the terminal slot. Gently tug the wires to verify that they are tightly held inside the terminal slot

- 10 Repeat this process with each of the remaining wire connections for **P1**, as shown in "Drawing 13: P1 power and data wiring" on page 28. Connect the earth ground to a true earth ground in the building: either a grounded water pipe or a copper rod in the ground as per code.

Drawing 13: P1 power and data wiring

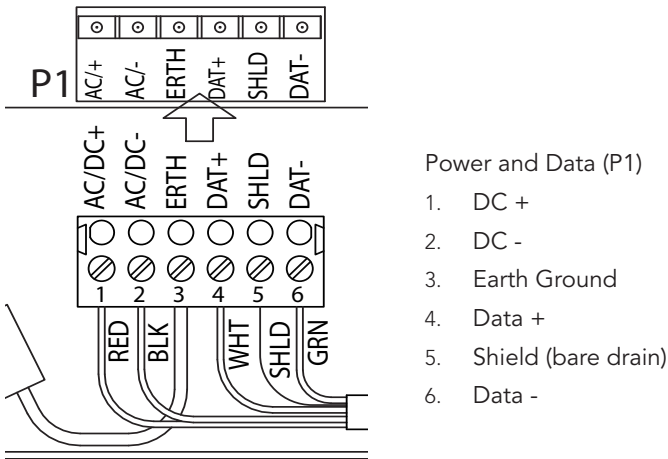

11 Connect an AI device (alarm, door strike, gate etc) to the multiplexer with terminal block **P2**. Use the configuration in “Drawing 14: P2 relay wiring” on page 29. Ensure all wires are tightened correctly according to steps 8 & 9.

Drawing 14: P2 relay wiring

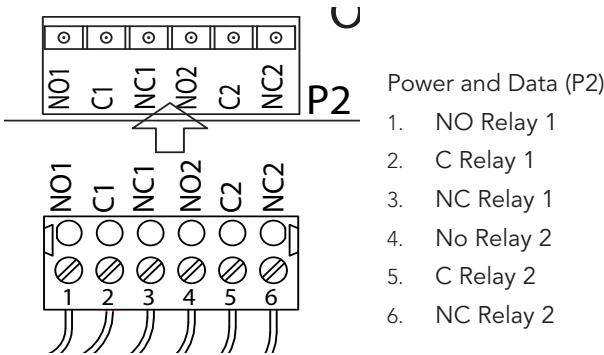

12 The receiver connects to the multiplexer using the connector in the upper right-hand corner of the board (**connector P8**).

Drawing 15: P8 relay wiring

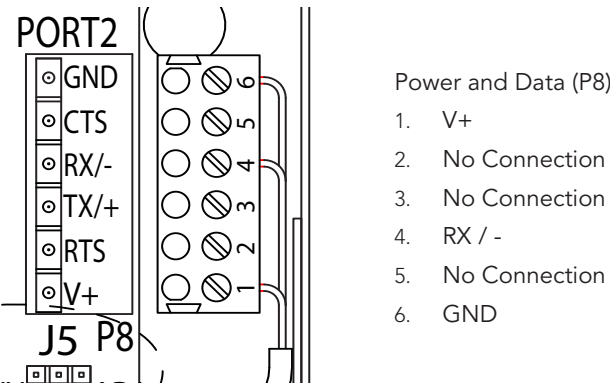

WIRELESS MODULE

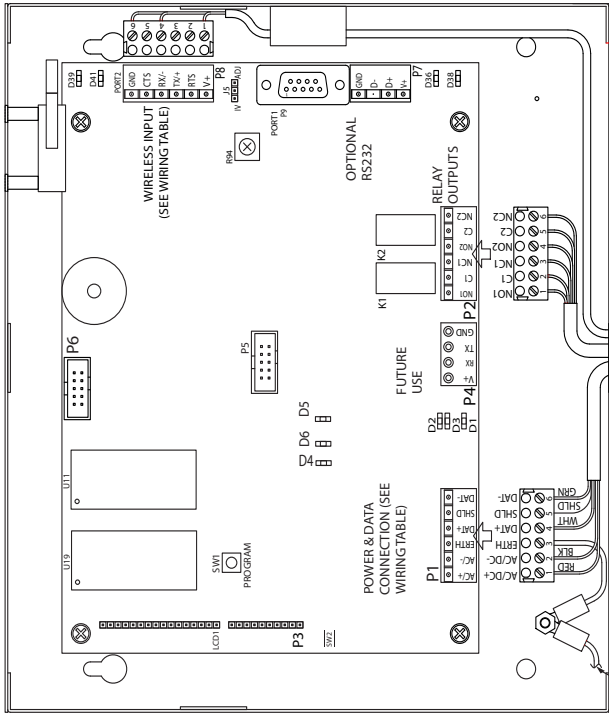

Drawing 16. Wireless multiplexer wiring

WIRING TABLE		
WIRELESS MODULE	WIRELESS RECEIVER	WIRE COLOR
P8-1 (V+)	Vs	RED
P8-4 (RX/-)	OUT 1	WHITE
P8-6 (GND)	GND	BLACK

WIRELESS RECEIVER

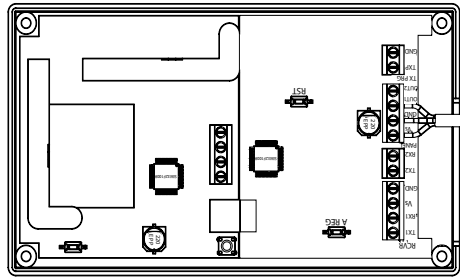

WIRELESS MODULE TO WIRELESS RECEIVER CABLE CAN BE UP TO 50 FEET LONG

TO ALARM, GATE OR DOOR STRIKE IF APPLICABLE (REFER TO DEVICE MANUFACTURER'S INSTRUCTIONS FOR PROPER WIRING)

FROM POWER SUPPLY & CONTROLLER IN OFFICE

CONNECT TO EARTH GROUND

Operating the Wireless Multiplexer

When operating properly, the wireless multiplexer display changes approximately every four seconds between showing the time and date and the last four events. The date and time on the display are set automatically from the controller once it is communicating.

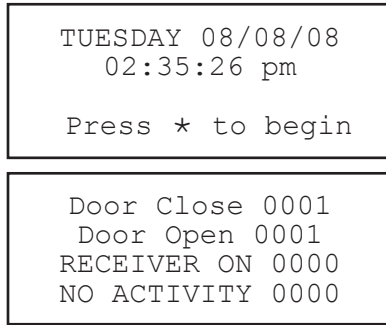

Pressing the * key will toggle through the various menu options available, in the following order:

Select the desired option by pressing the # key when it is shown on the display. If CANCEL is selected or no key is pressed in a short period of time, the display will resume normal operation.

- | | | | |
|---|--|---|---|
| 1 | REGISTER A SINGLE DOOR TRANSMITTER?
Press * to Change
PRESS # WHEN DONE | 4 | ENTER SETUP MODE?
Press * to Change
PRESS # WHEN DONE |
| 2 | REGISTER A RANGE OF DOOR TRANSMITTERS?
Press * to Change
PRESS # WHEN DONE | 5 | DISPLAY UNIT ID?
Press * to Change
PRESS # WHEN DONE |
| 3 | CLEAR A SINGLE DOOR REGISTRATION?
Press * to Change
PRESS # WHEN DONE | 6 | CANCEL
Press * to Change
PRESS # WHEN DONE |

Displaying the Multiplexer Address and ID

To display the multiplexer address and ID, press the * key on the multiplexer until the display shows "DISPLAY UNIT ID?", then press the # key. The display will then show the part number of the multiplexer, the address it is set for, and the serial number of the device. The display will be similar to:

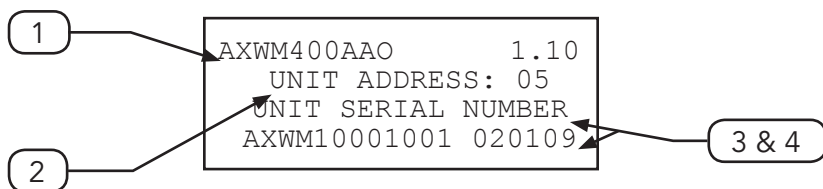

Line one	the part number of the multiplexer and the firmware revision.
Line two	the address of the multiplexer on the RS485 communication line. This address is used by the controller to communicate with the multiplexer. It must be unique and not shared by any other device attached to the system.
Line three and four	the serial number of the multiplexer and the manufacturing date code

This is the easiest way of checking the address of the device. This display will also show for a few seconds when the multiplexer is first connected to power.

Setting the Operating Parameters via 'Setup Mode'

The operating parameters determine how the display will appear and the unit will function. Setup mode allows changes to the operating parameters for customization. To enter setup mode, press the * key until the display shows:

ENTER SETUP MODE?

Press * to Change,
PRESS # WHEN DONE

When this display appears, press the # key to enter setup.

The multiplexer will ask for the setup password, the factory default password is 8898. If an invalid password is entered, the multiplexer will resume normal operation. The numeric password code should be changed to restrict access to Setup Mode.

When the correct setup password is entered, the multiplexer display changes and prompts for the unit address. The following sections describe each of the setup parameters in the order in which they appear

Unit Address

```
Current Address: 005
Enter New Address:

PRESS # WHEN DONE
```

The Unit Address is the address of the multiplexer on the RS485 communications line. This parameter must be set for the multiplexer to operate error-free.

The address must be unique, make sure no other devices on the network use the same address.

The valid address range is from 1 to 127 for a Falcon XT and 1 to 31, for a Falcon Base Unit. Do not use address 22 as it is reserved by the controller.

If an improper address is entered, the display will show an invalid address message and repeat the prompt for the address. The factory default for the address is 1.

Communications Rate

The Communications Rate is the baud rate used by the controller to communicate to the multiplexer. Press the * key to step through the available options.

```
Communications Rate:
9600 baud
Press * to Change,
PRESS # WHEN DONE
```

NOTE: The controller can only communicate to remote devices at 1,200 and 9,600 baud. The other available options are for future use. The factory default setting is 9,600 baud.

Backup Baud Rate

This function sets the baud rate for the serial port on the mux, used to communicate to the RX900 backup / restore utility program. The factory default setting is 19200 baud.

```
Backup Baud Rate:
  19200 baud
Press * to Change,
PRESS # WHEN DONE
```

Change Setup Password

```
Change the Setup
  Password?
Press * to Change,
PRESS # WHEN DONE
```

Change Setup Password changes the factory default setup password. While this message is displayed, press the # key, the multiplexer will prompt for a new numeric password.

Enter the new password, enter the same new password again for verification. If both entries match, the new password will be set and the display will continue to the next parameter.

If the passwords do not match, the display will show a warning that the passwords do not match and then revert back to the 'Change Setup Password' screen.

Tamper Sensor Enable/Disable

```
Tamper Sensor is:  
    ENABLED  
Press * to Change,  
PRESS # WHEN DONE
```

The Tamper Sensor parameter enables/disables the tamper switch. When **ENABLED**, the multiplexer will send a tamper alarm to the controller if the door to the multiplexer is opened. When **DISABLED**, the tamper sensor is ignored.

This only affects the tamper sensor on the multiplexer case. It does not enable or disable tamper alarms from the wireless transmitters. The factory default is **ENABLED**.

Beep with Key Press

Beep with Key Press controls the buzzer on the system. When set to **YES**, the multiplexer will produce a very short beep when a key is pressed. Installers have an additional signal to verify entries from the keypad. The factory default is **YES**.

```
Beep with Key Press?  
    YES  
Press * to Change,  
PRESS # WHEN DONE
```

Date Format

```
Date Format:  
    US  
Press * to Change,  
PRESS # WHEN DONE
```

The Date Format parameter controls the format of the date shown on the display. It does not affect the date or time from the controller. The options are **US** format and **EUROPEAN** format. The factory default is **US**.

Time Format

```
Time Format:
  12 Hour
Press * to Change,
PRESS # WHEN DONE
```

The Time Format parameter controls the format of the time shown on the display. It does not affect the date or time from the controller. The options are 12 Hour and 24 Hour. The factory default is 12 Hour.

Check in Fail Time

```
Check-In Fail Time:
  in minutes: 240
Press * to Change,
PRESS # WHEN DONE
```

Check in Fail Time controls the length of time the Multiplexer gives a door transmitter to check in before the Multiplexer assigns a "Failed to Report" to the transmitter. Door transmitters must check in at least once during this time period. The time is set in minutes, current factory default is 240 minutes.

Relay 2 Function

Relay #2 Function:
ALARM OUTPUT
Press * to Change,
PRESS # WHEN DONE

Relay 1 on the multiplexer is always set to function like the relay on any keypad or access control device. It can also function as a relay board relay, if desired. The Relay 2 Function parameter controls the operation of Relay 2 on the multiplexer. The available options are:

- Alarm Output
- Hold Open by Time
- Slave to Relay 1
- Different Hold Time
- Aux. Output.

Alarm Output

Sets Relay 2 to activate when the controller sends an alarm. In this mode, it can be used to trigger an external siren or strobe light. The controller determines the length of time the relay will be active.

Hold Open by Time

Allows Relay 2 to activate or deactivate at a specific time of day. Each day of the week can have different activate and deactivate times.

As an example, the relay can be used to Open or Close a secondary gate. (The **activate** time is referred to as the open time and the deactivate time is referred to as the close time. In this scenario the multiplexer will prompt for the open and close times for each

day of the week Monday through Sunday. It will also ask for the Holiday open and close times, and the next holiday date. The multiplexer will automatically track the date and time and control the relay accordingly.

Slave to Relay 1

Causes Relay 2 to activate when Relay 1 activates and release when Relay 1 deactivates. This option is used when relays are controlling a gate or other device that requires two isolated relays.

Different Hold Time

This function activates Relay 2 when Relay 1 activates but deactivates Relay 2 at a different time. When selected, the multiplexer prompts for the Relay 2 hold time. Note: Relay 1 activity time is always controlled from the controller. This option is designed to work with devices that use different hold times. It can also be used to activate a door holder.

Aux. Output

Enables Relay 2 to act as a second relay on the multiplexer. When this option is selected, the relay will function just like a relay on any relay board.

Restore Factory Settings

The wireless multiplexer can restore the factory defaults. To restore the default settings, hold the program switch while connecting power to the multiplexer. The display ask if you want to restore the factory defaults. Select **YES** to restore the parameters to the factory defaults. Remember to set the address and baud rate after restoring the parameters.

Register Transmitters

Every transmitter has a unique identification number programmed from the factory. The wireless multiplexer uses this identification number to determine which transmitter is sending data. The identification number is not the same as the channel number and each transmitter must also be registered to a channel within the wireless multiplexer before it will function.

Once a transmitter is registered with a channel, the multiplexer looks up the transmitter's channel number when it receives data from the transmitter. This helps prevent unwanted or unknown signals from interfering with system operation.

Transmitters can be registered one at a time or in a group. Use the, REGISTER A SINGLE TRANSMITTER, when adding or replacing a transmitter. Use the REGISTER A RANGE OF TRANSMITTERS when adding several transmitters to a site at one time.

Register a Single Door Transmitter

The process for registering a single door transmitter is shown in Drawing 17 on page 41. The displayed messages are shown to the right of the prompts.

To begin, press the * key on the multiplexer until the REGISTER A SINGLE DOOR TRANSMITTER message displays, then press the # key.

The multiplexer will beep when it recognizes the reset of a transmitter. This is an audible signal that the transmitter has been registered

When the multiplexer is waiting for a reset on a transmitter, the timeout is disabled and you must manually complete the operation using the keypad.

Drawing 17: Register a single door transmitter

'A REG' BUTTON ON
TRL8080 BOARD LOCATED
INSIDE RECEIVER

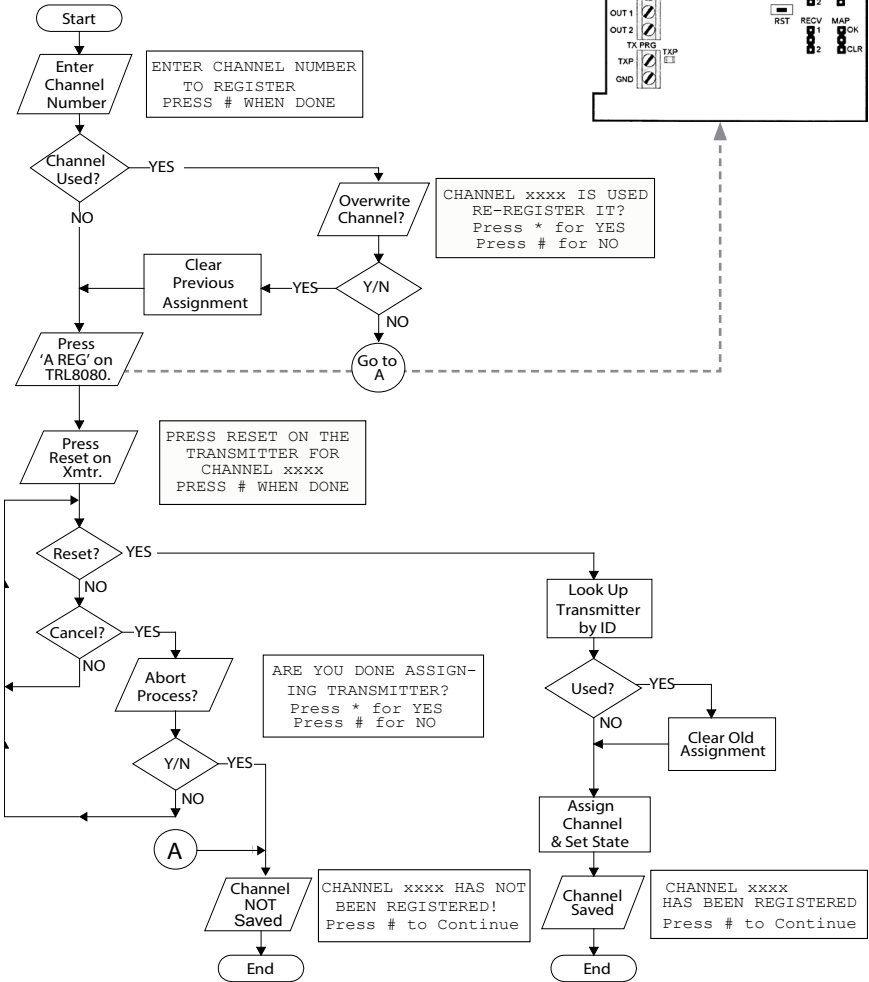
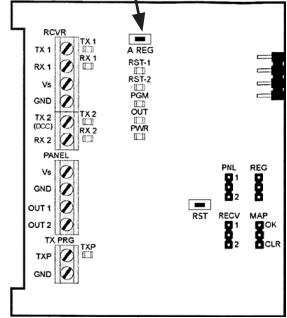

Register a Range of Door Transmitters

While using this function, the multiplexer ignores activity from all other transmitters. Therefore you should only register new channels when there is low activity on the site.

This function allows you to register a group of transmitters to a range of channels. The channels will be sequential beginning with the starting channel entered.

- 1 The process for registering a range of transmitters is shown in "Drawing 18: Register a range of transmitters" on page 4341. The displayed messages are shown to the right of the decision icons.
- 2 To begin the process, press the * key on the multiplexer until the REGISTER A RANGE OF DOOR TRANSMITTERS option displays, then press the # key.
- 3 The multiplexer prompts for the first channel number to use and automatically counts sequentially to the next channel when a transmitter is registered.
- 4 The multiplexer will not allow a transmitter that is already assigned to another channel to be registered as part of a group. Use the Register A Single Door Transmitter function to reassign transmitters that have already been registered.
- 5 The multiplexer will beep when it recognizes a transmitter reset. This is an audible confirmation that the transmitter has been registered and the channel number will automatically count up.

Drawing 18: Register a range of transmitters

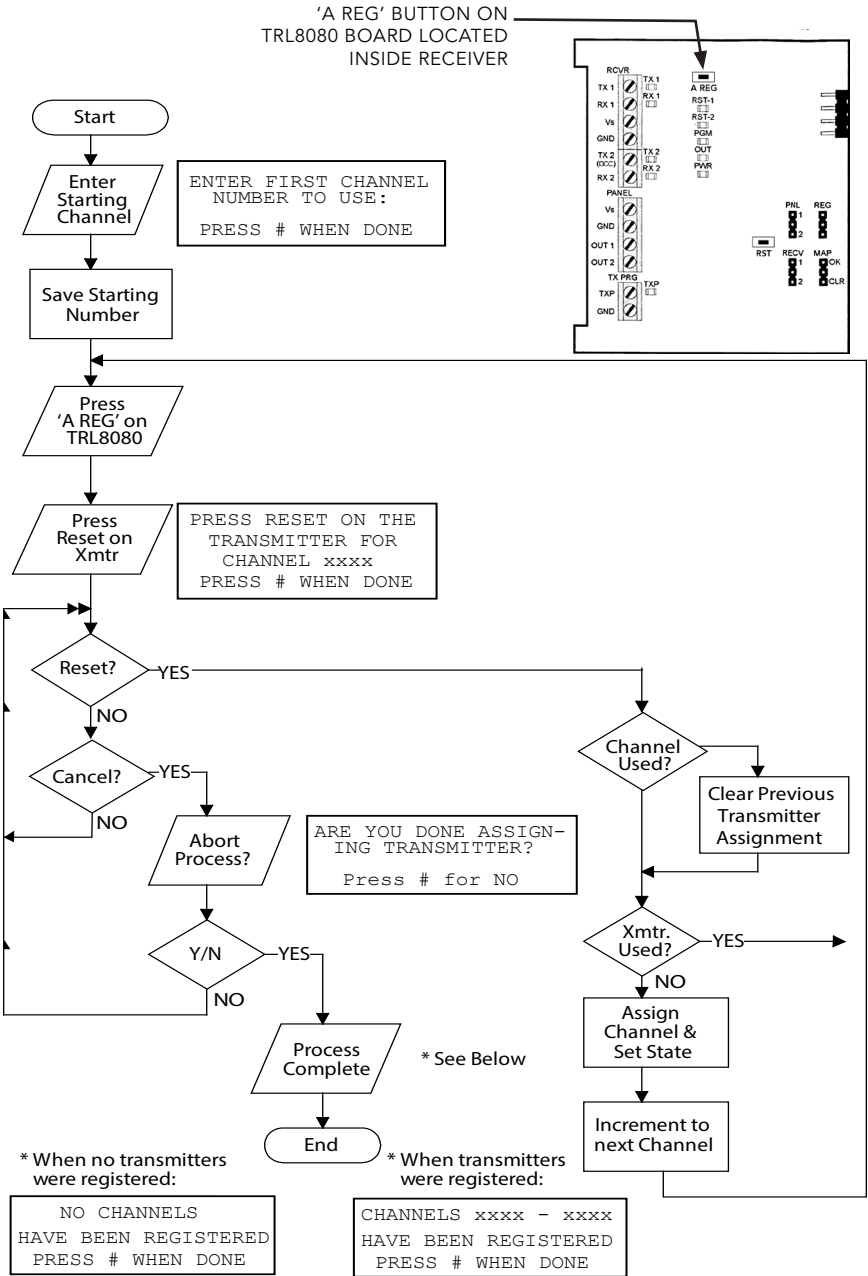

- 6 On other menu options, the multiplexer has a timer that will revert the multiplexer back to its idle state if there is no input from the keypad for a period of time. However, during this function, while the multiplexer is waiting for a transmitter reset, the timeout is disabled and you must manually end the operation using the keypad.

Clearing Transmitter Registrations

Clearing Transmitter Registrations is used to remove the channel assignments from the multiplexer. Use this function when removing or replacing transmitters.

Clear a Single Channel Registration

This function clears a single transmitter registration. Use this option when removing or replacing a transmitter.

To use the option, press the ***** key on the multiplexer until the CLEAR A SINGLE DOOR REGISTRATION message displays, then press the **#** key. The multiplexer prompts you to enter the channel number to be removed. When a registered channel number is entered, the multiplexer asks if you are sure you want to remove the channel. When Yes is selected, the channel registration will be cleared.

Clear All Channel Registrations

This clears all the registration information, all transmitters on the site will have to be registered again. Be careful not to use this option unless you are planning on resetting every transmitter on the site.

This function clears all transmitter registrations from the multiplexer, only use this function when the site is being reconfigured.

To begin the process, press the * key on the multiplexer until the CLEAR ALL DOOR REGISTRATIONS option displays, then press the # key.

The system will ask if you are sure you want to remove all registrations, select YES to begin the process. While clearing all registrations, the multiplexer will display the following message:

```
* PLEASE WAIT *  
  
Clearing Channel  
Registrations
```

This process takes several minutes to complete, during which the controller will report that the multiplexer has lost communication. Communication will restore once the process is complete.

Setting Up the Controller

To ensure that the multiplexer operates properly, it must be set up in the access control system as a multiplexer.

If using a Falcon base unit system, make sure the controller firmware is at least Version 4.10.

With the correct version of firmware, use the Setup Remotes function to configure the remote. The controller refers to the remote devices only by the address on the RS485 line.

For the wireless multiplexer, configure the remote in the controller to be a multiplexer.

The controller only refers to doors by the multiplexer and channel number assigned to it, not the physical location or unit number

The most important step in the installation process is programming a cross-reference table on the system between the physical door/unit numbers on-site, the multiplexer number, and channel number.

It is good practice to **copy this information and leave it in more than one location** (one with the installer, one at the site etc.) for future reference. Should the system need to be reprogrammed, it is very hard to recreate this data.

This cross-reference table turns multiplexer and channel numbers, as read by the controller, into unit numbers which are used in reported event messages on-screen.

This programmed reference table is the only way an end-user can physically locate remote devices on their site when the controller reports an event.

During the physical install and channel programming, the installer must write down the unit number on which each door transmitter is installed. A sample format is:

Door or Unit Number	Multiplexer Number	Channel
A0001	3	0001
A0002	3	0002

The Multiplexer Number is the address of the wireless multiplexer. The Channel Number is the channel to which the transmitter is assigned. Use the blank worksheet on page 78 to track this information.

In addition, **back up the data in the multiplexer electronically after programming is finished** (using PTI's backup utility). If the mux is ever damaged, the data can quickly be restored.

Reported Events

The multiplexer has several different events that it reports for each transmitter. The following list of events is listed as they appear on the display of the multiplexer. Each event is followed by a description of the event and how it reports from the controller.

Door Open 0001

- Reports the opening of a door.
- The numbers following the message are the transmitter's registered channel numbers.
- The controller looks up the channel number in the cross-reference table.
- If the channel is not assigned, the event will report as `Unknown Door Open` with a reference to the multiplexer and channel numbers.
- If the channel is assigned, the event reports as `Door Open` or `Door Alarm` with a reference to the unit number. This message is conditional, depending if the tenant of the unit is on-site.
- The actual reporting of the event depends on the configuration of the controller.

Door Close 0001

Reports the closing of a door.

- The numbers following the message are the transmitter's registered channel numbers.
- The controller looks up the channel number in the cross-reference table.
- If the channel is not assigned, the event reports as `Unknown Door Close` with a reference to the multiplexer and channel numbers.
- If the channel is assigned, the event will report as `Door Close` with a reference to the unit number.
- The actual reporting of the event depends on the configuration of the controller.

Tamper Alarm 0001

- Reports that a transmitter has been tampered with.
- The numbers following the message are the transmitters' registered channel numbers.
- The controller looks up the channel number in the cross-reference table.
- If the channel is not assigned, the event reports as Unknown Tamper Alarm with a reference to the multiplexer and channel numbers.
- If the channel is assigned, the event will report as Unit Tamper Alarm with a reference to the unit number.
- The actual reporting of the event depends on the configuration of the controller.

Tamper Secure 0001

- Reports that a transmitter is now secured from the tampered state.
- The numbers following the message indicate the channel number to which the transmitter is registered
- The controller looks up the channel number in the cross-reference table.
- If the channel is not assigned, the event reports as Unknown Tamper Secure with a reference to the multiplexer and channel numbers.
- If the channel is assigned, the event will report as Unit Tamper Secure with a reference to the unit number.
- The actual reporting of the event depends on the configuration of the controller.

```
Unit Comm. Off  
0001
```

- Warns that a transmitter has not reported in the required time.
- Each transmitter is scheduled to report to the multiplexer within a fixed amount of time.
- If a transmitter fails to report, the multiplexer records this event and sends it to the controller.
- The numbers following the message are the transmitter's registered channel numbers.
- The controller looks up the channel number in the cross-reference table.
- If the channel is not assigned, the event reports as Unknown Check in Fail with a reference to the multiplexer and channel numbers.
- If the channel is assigned, the event will report as a Unit Check in Fail with a reference to the unit number. Depending on the settings in the controller, this event can also sound the alarm siren.
- **To get attention, the multiplexer sends this notification to the controller every four hours until the problem is corrected.**

```
Unit Comm. On 0001
```

- Indicates that a transmitter has begun reporting to a multiplexer after it has been off.
- The numbers following the message are the transmitters' registered channel numbers.
- The controller looks up the channel number in the cross-reference table.
- If the channel is not assigned, the event reports as Unknown Check in Restore with a reference to the multiplexer and channel numbers.
- If the channel is assigned, the event will report as Unit Check in Restore with a reference to the unit number.
- The actual reporting of the event depends on the configuration of the controller.

Low Battery 0001

- The multiplexer monitors each transmitter for battery condition.
- Transmitters begin to report a low battery condition to the multiplexer at least one week before their batteries fail.
- The numbers following the message are the transmitters' registered channel numbers.
- The controller looks up the channel number in the cross-reference table.
- If the channel is not assigned, the event reports as Unknown Low Battery with a reference to the multiplexer and channel numbers.
- If the channel is assigned, the event will report as Unit Low Battery with a reference to the unit number.
- The actual reporting of the event depends on the configuration of the controller.
- **To get attention, the multiplexer sends this notification to the controller every six hours until the problem is corrected.**
- See "Battery Replacement" on page 62 for more information.

Receiver On 0001

- Indicates that the multiplexer is in contact with the receiver.
- This event always shows a channel number of 1 and reports every time the multiplexer is powered on or when the receiver is connected after being off.
- It reports to the controller as Data Comm. One - Controller 1 referenced to the multiplexer number.

Receiver Off 0001

- Indicates that the multiplexer has lost the connection to the receiver
- This event always shows a channel number of 1 and will report to the controller as `Data Comm. Off - Controller 1` and reference the multiplexer number. Depending on the settings in the controller, this event can sound the alarm siren

No Activity 0000

- This message does not report to the controller. It will only show after the multiplexer is powered up.

Multiplexer Tamper Alarm

- This event does not show on the display of the multiplexer. It reports to the controller as a `Tamper Alarm` with a reference to the multiplexer number. It indicates that the multiplexer door has been opened.
- Reporting this event can be disabled in the multiplexer setup. Depending on the settings in the controller, it can also sound the alarm siren.

Multiplexer Tamper Secure

- This event does not show on the display of the multiplexer. It reports to the controller as a `Tamper Secure` with a reference to the multiplexer number. It indicates that the multiplexer door has been closed.
- Reporting this event can be disabled in the multiplexer setup.

Wireless Repeaters

PTI Wireless Repeaters can boost the signal from door transmitters when they are too far away from the receiver, located in high noise areas, or installed where objects interfere with the signal. The actual number of repeaters needed will vary from site to site depending on several factors.

Repeaters must be installed near a standard 120 V outlet and each repeater has a low voltage power pack with a rechargeable battery. The battery provides backup power for the repeater in the event of a power failure.

How Many Repeaters are Needed?

In ideal conditions the receiver can pick up signals from door transmitters up to 1,500 feet away. For most installations, particularly sites with metal construction, at least one repeater should be installed for any door transmitters located over 400 feet from the receiver,

Repeaters should be mounted so that every transmitter has multiple transmission paths to the receiver. This kind of redundancy improves system integrity in the event of any temporary interruptions to a transmission path on the site.

Repeaters can “hopscotch” messages from one to another, so that if any one repeater cannot talk directly to the receiver, the message will be transferred through other repeaters until it gets to the receiver.

Repeaters transmit at a much higher power than door transmitters, allowing the repeaters to be spaced much further apart than transmitters. The repeater(s) location is determined by the placement of the transmitters.

There are two methods for calculating the number of repeaters needed for a site: site survey and post-installation test. Each method varies in complexity and equipment required.

Site Survey

The most accurate way to locate the optimum position for repeaters is through a site survey. PTI Security Systems has a site survey kit available for trained installers.

The survey kit allows the installer to read the signal strength of every door transmitter on the site at the receiver. Repeaters are then located where the signal strength readings are weak.

NOTE: the installer must be specifically trained in the operation of the PTI survey kit.

Post Installation Test

Though less accurate than a site survey, this method still provides good placement locations for repeaters.

Always perform a walk-through test after mounting each repeater, activating each transmitter near its location and checking for an appropriate response. After the security system is completely installed, the installer tests every door transmitter on the site over a period of one to two days. The installer looks for transmitters that fail to check in or do not report door activity. This indicates a weak signal to the receiver.

Repeaters are then installed near the transmitters that exhibit these symptoms. The repeaters' increased signal strength creates overlaps in their transmission range, resulting in stable signal strength throughout the site.

Repeater Location

Place repeaters as high as practically possible, in a sheltered location, as far away from metal objects (duct work, mesh screens, boxes), and not subject to physical damage. Repeaters should be mounted with as few obstacles as possible between them and their receiver. Each repeater must be installed near a 120 VAC outlet, or run wiring from the nearest outlet to the repeater.

Installing the Repeaters

- 1 Determine the repeater location and mount the weatherproof housing.
- 2 Mount the repeater in the housing vertically so that the antennae are oriented as shown in "Drawing 18: Repeater wiring" on page 53 and the cable opening faces downwards.
- 3 Use a small screwdriver to press the housing release tab on the top or bottom of the repeater to separate the housing.
- 4 Connect the internal battery from the backup battery into the battery connector as shown in Drawing 18
- 5 Connect the external power supply at the point shown in Drawing 18 using 20 AWG or larger wire. Route the cable from the transformer to unit through the left side of the repeater or through the oval knock-out section in the rear.
- 6 The repeater is shipped with a low voltage wall transformer. This transformer must be plugged into an unswitched 120 VAC outlet. The transformer must be secured to the outlet using the tab on the transformer, this prevents it from being accidentally unplugged.
- 7 The transformer must be connected to the repeater using 20 AWG or larger wire. **The length of the wire from the transformer to the repeater should not exceed 325 feet.**

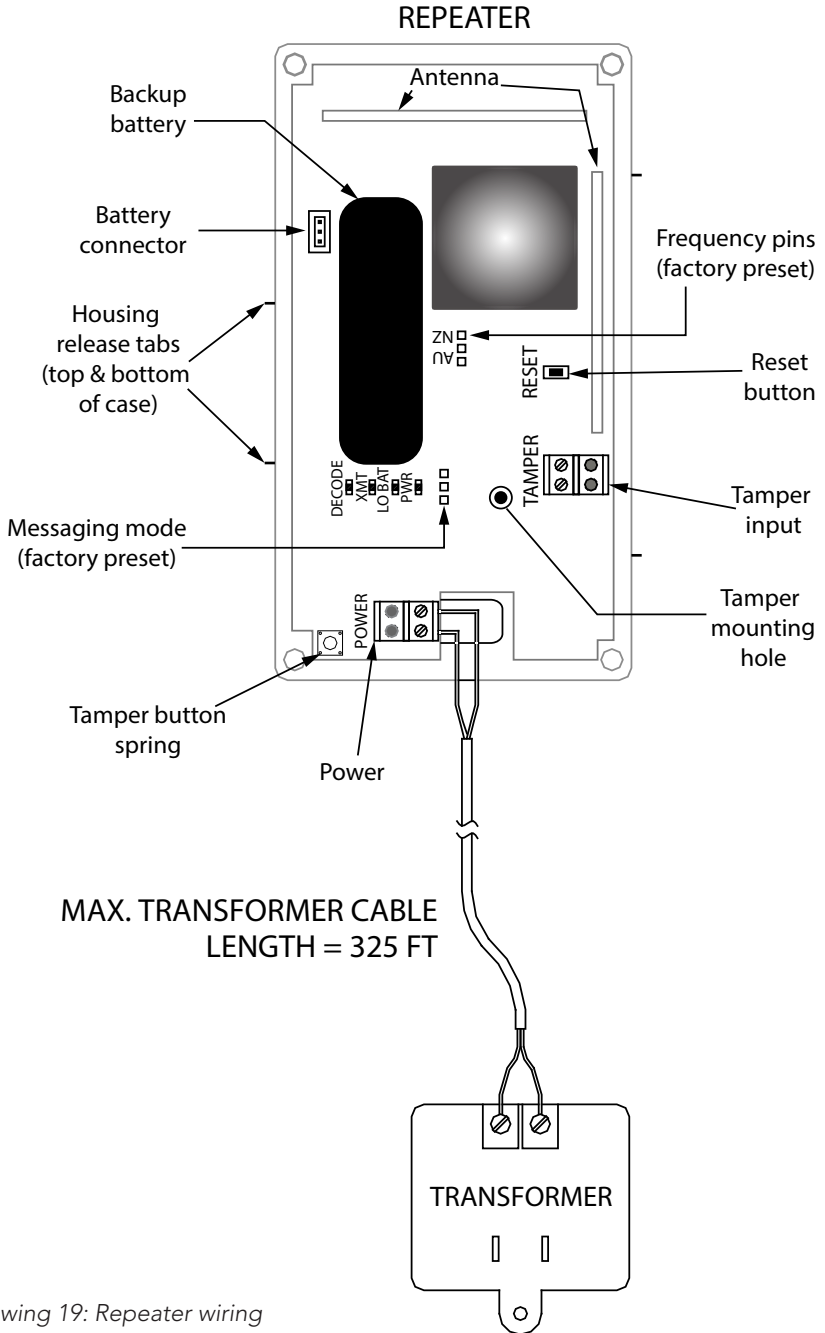

Drawing 19: Repeater wiring

Testing the Installation

The wireless door alarm system testing process can usually take a few hours to complete for most installations. Testing consists of four basic diagnostic procedures:

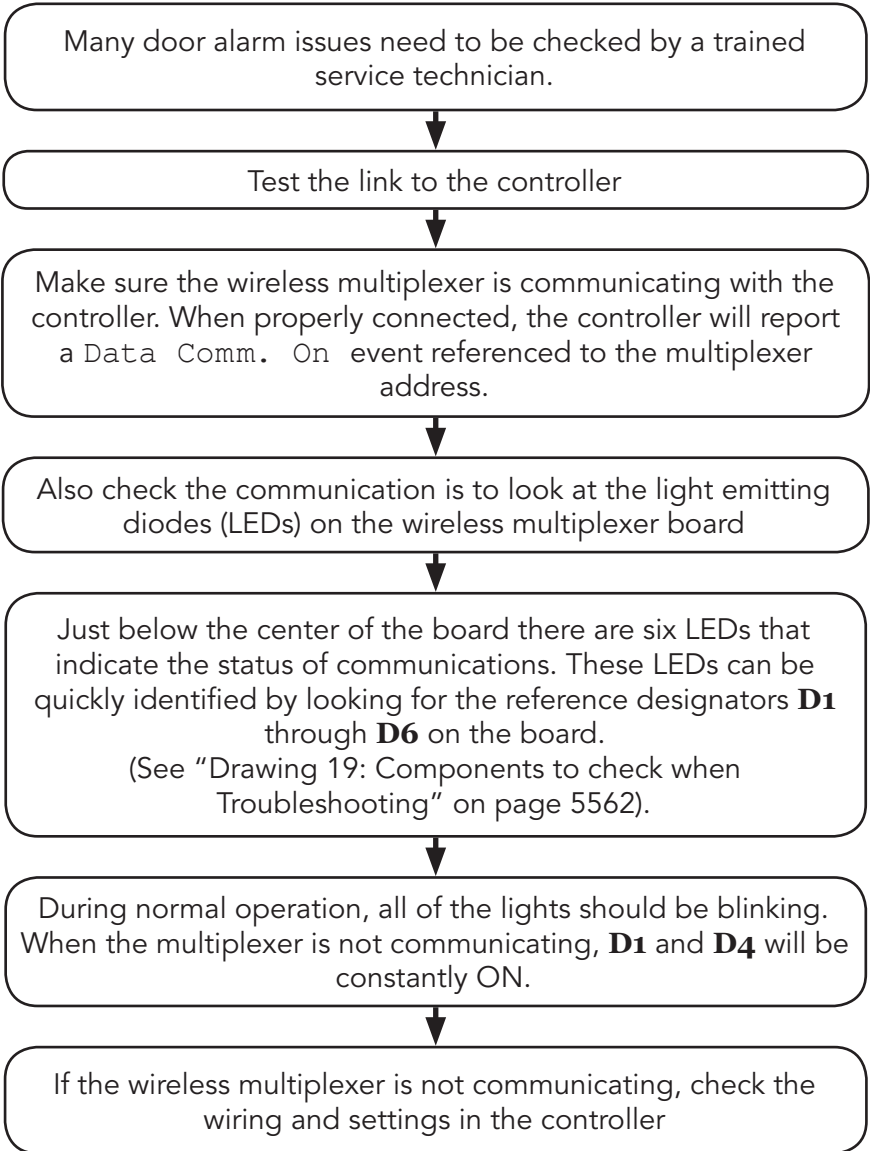

Test the wireless receiver

Make sure the wireless multiplexer is communicating with the wireless receiver

The wireless multiplexer has two light emitting diodes (LEDs) in the upper right-hand corner of the board that indicate the communication status with the wireless receiver.

The LEDs have reference designators **D39** and **D41** on the board (See "Drawing 19: Components to check when Troubleshooting" on page 5662).

When the wireless multiplexer is communicating with the wireless receiver, these LEDs will blink periodically. The diodes also blink with door activity.

If one of the diodes is ON all the time or they do not blink at all, check the wiring and the connections between the wireless multiplexer and the wireless receiver.

Test the repeaters

Check that the wireless repeaters are working by looking at the lights on the front of the repeater.

Remove the cover on the weatherproof enclosure. There are five LED lights on the front of the repeater. The LED at the top is labeled **AC** and should constantly lit.

See "Drawing 20: Repeater LEDs" on page 57.

If the power goes out, the LED labeled **BATTERY** will light up.

When the repeater is working, the LED's labeled **DECODE** and **TRANSMIT** blink periodically when the repeater is receiving and relaying signals to receiver.

The LED labeled **NOT ACTIVE** only lights for a few seconds after powering up the system

If the **NOT ACTIVE** light is on, try resetting power to the wireless multiplexer

Test the door transmitters

Slide a thin piece of ferrous metal between the magnet and the transmitter housing - an electrical junction box cover works very well.

Make sure that the metal used is not copper, brass, or aluminum. A magnet must stick to the metal for it to work.

To test the doors, slip the metal plate between the magnet and the transmitter housing. Hold it in position for two to three seconds, then remove it.

If the door transmitter is working properly, the controller will show a `Door Open` or `Door Alarm` event followed by a `Door Close` event and a reference to the unit number.

If the controller does not show any activity, check the transmitter installation carefully.

If the controller shows an `Unknown Door Open` and an `Unknown Door Close`, the door table reference is wrong in the controller.

(The door table may not have been downloaded)

If the door table is right, the correct unit number will appear. If not, the door table needs to be updated or the system will not operate properly.

System Maintenance & Troubleshooting

System Maintenance

The wireless door alarm system requires periodic maintenance. When the recommended maintenance is performed regularly, the system will provide the best possible security for your site.

Periodic Visual Inspection

Because the door transmitters are mounted on the outside of doors, a visual inspection is very easy. **PTI recommends that all door transmitters are inspected every month:**

Look for visible signs of damage or wear. Check the doors to make sure the magnets are still in alignment and there is no excessive movement in the door.

Monitor the Door Activity Reports

The site manager should regularly go over the site activity reports to look for unusual activity. Reports can be found in the access control software.

For example, if a report shows an entry and an exit for a tenant but does not show any door activity for the tenant's unit, then the door transmitter may not be functioning properly. Inspect and test any door transmitters that may not be working properly.

Activity reports also show low battery alerts or a unit that is not checking in. Physically check the individual transmitter involved. Reports can be found in the access control software.

Battery Replacement

Battery life in the door transmitters depends on several factors, including the amount of activity. A `Low Battery` condition begins to report approximately one week before the battery is completely drained.

This report resends to the wireless mux display and access control software every six hours until the battery is changed. Under normal conditions, the battery should last for between two and five years.

Battery replacement should be a scheduled maintenance item for the site. Once a transmitter begins reporting a low battery, all batteries should be replaced at once to reduce maintenance costs.

Troubleshooting

For a **new installation**, typical problems are related to the installation or configuration process. Start at step #1 on page 65 and continue until the problem is found and resolved.

Existing installation (previously working)

Determine whether anything has been changed at the site. For instance, Has there been any new construction? This includes any changes to the site, adding units, reconfiguring units, changing or adding video surveillance components, changing any electrical wiring, roofing changes, painting, etc. Even with a small change, wiring can be disturbed or disconnected or something new can interfere with equipment operation.

If the wireless multiplexer is not working, start at **Step #1** and proceed until the problem is found and corrected

If the multiplexer is working but no door activity is reported, start at **step #7** and proceed until the problem is found and corrected.

If some doors are reporting activity but others are not, start at **Step #11** and proceed until the problem is found and corrected.

If a group of transmitters has stopped working, start at **step #16** and proceed until the problem is found and corrected.

Refer to “Testing the Installation” on page 57 for more information on isolating problems. Make sure the problems are not related to routine maintenance, including battery replacement.

WIRELESS MODULE

Drawing 20: Components to check when Troubleshooting

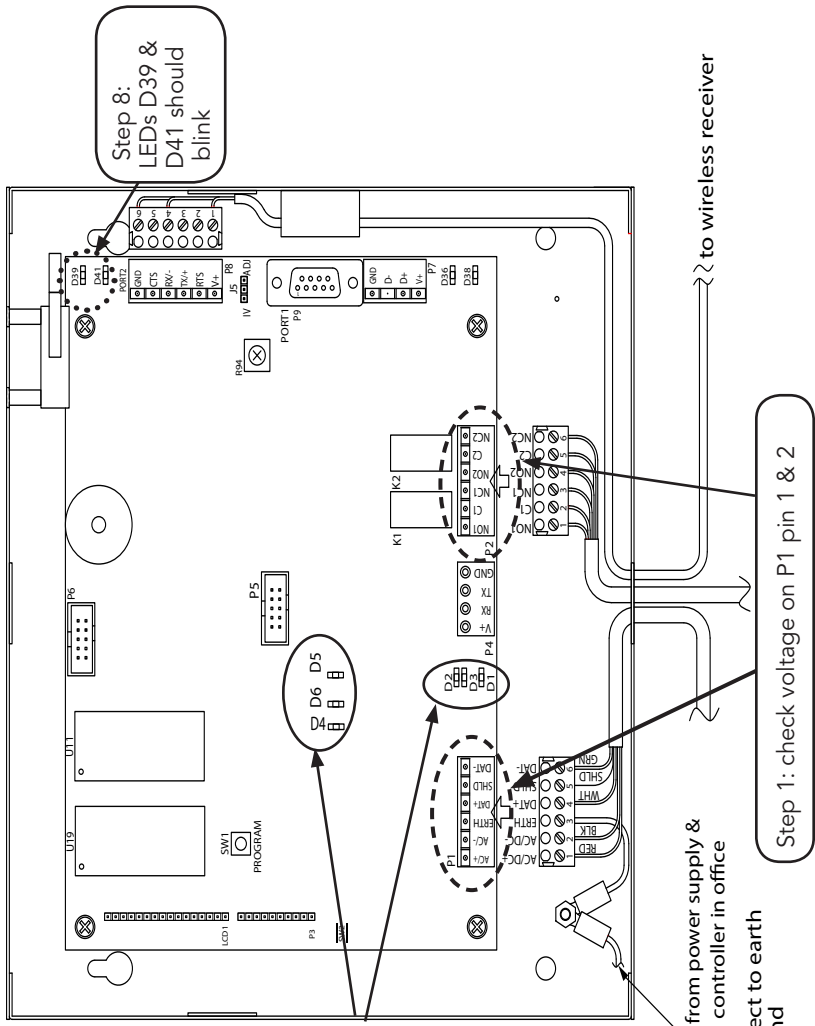

1 Does the wireless multiplexer have power?

Check the multiplexer display. If the display is on or if any of the LEDs on the board are on, the board has power.

If there is no indication of power from the display or LEDs, use a voltmeter to check for any voltage on **connector P1 pins 1 and 2**. See "Drawing 20: Components to check when Troubleshooting" on page 64

Yes – Proceed to Step 2

No – Check Power Supply and Wiring and retest

2 Is the voltage at the wireless multiplexer higher than 10.5 Volts?

Use a voltmeter to measure the voltage on **connector P1 pins 1 and 2**

Yes – Proceed to Step 3

No – Check Power Supply and Wiring and retest

3 Is the wireless multiplexer display blank?

Yes – Contact Technical Support

No – Proceed to Step 4

4 Is the wireless multiplexer communicating with the controller?

Check the LEDs on the wireless multiplexer board or run the system setup report on the controller.

When the wireless multiplexer communicates with the controller, **LEDs D1 – D6** will be blinking. See Drawing 20 on page 64.

If **only D1 and D4** are blinking, proceed to Step 6.

YES – Proceed to step 7

NO – Check wiring and proceed to Step 5

5 Are any other devices set to the same address as the wireless multiplexer?

Check the addresses on all of the devices, or disconnect the wireless multiplexer and run the system setup report on the controller.

If the system setup report shows the remote number (address) assigned to the wireless multiplexer as being **ON LINE** while the multiplexer is disconnected, then another device is sharing the same address.

Do not use address 22 as it is reserved by the controller.

Yes – Change one of the devices and retest

No – Proceed to the Step 6

Falcon Base Unit only

6 Is the Maximum Remotes in the controller set to a number higher than the address of the wireless multiplexer

Run the system setup report from the controller. If the value is LOWER than the wireless multiplexer address, the controller will not try to communicate with it.

Yes – Proceed to Step 7

No – Check the wireless receiver and retest

7 Is the wireless receiver connected to the wireless multiplexer?

The wireless receiver is connected to the wireless multiplexer at connector **P8** located in the upper right-hand corner of the wireless multiplexer board.

Yes – Proceed to step 8

No – Check the connection and wiring, reset the wireless multiplexer and retest

8 Is the wireless receiver communicating with the wireless multiplexer?

Check the LEDs in the upper right-hand corner of the wireless multiplexer board.

When the wireless receiver is connected and working properly, LEDs **D39 and D41** will blink whenever there is door activity at the site. See Drawing 20 on page 64

Additionally, when the wireless multiplexer is powered up, the display on the wireless multiplexer will show RECEIVER ON 0001 if the wireless receiver is connected.

Yes – Skip to Step 10

NO – Proceed to Step 10

9 Does the display on the wireless multiplexer show any activity besides Receiver On?

Yes – Proceed to Step 10

NO – Register the transmitters and retest

10 Have any transmitters been registered to the wireless multiplexer?

Yes – Proceed to Step 11

NO – Register the transmitter and retest

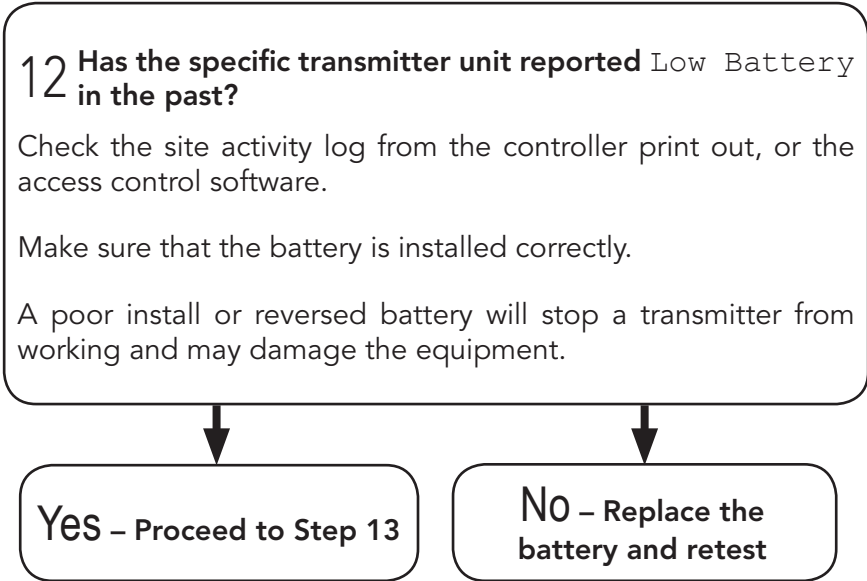
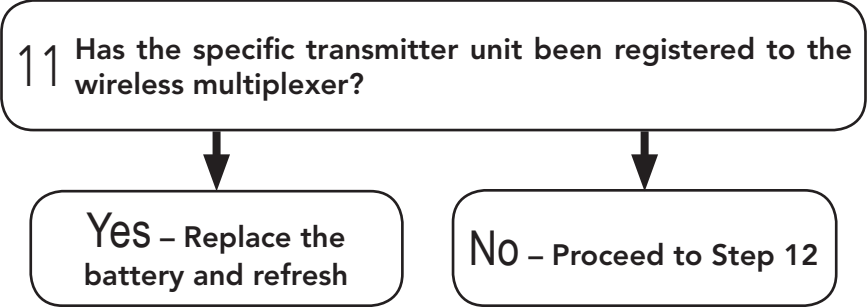

13 Does the battery in the transmitter read more than 2.6 VDC on a meter?

Yes – Check the magnet alignment and retest

No – Proceed to Step 14

14 Does the specific transmitter unit report any activity at all? (Tamper, Door Open etc?)

Yes – Replace the transmitter and send the faulty unit to PTI Security Systems for testing

No – Proceed to Step 15

15 Does a different transmitter work in the same location?
Use a voltmeter to measure the voltage on **connector P1 pins 1 and 2**

Yes – Proceed to step 16

No – Fix the repeaters and retest

Drawing 21: Repeater LEDs

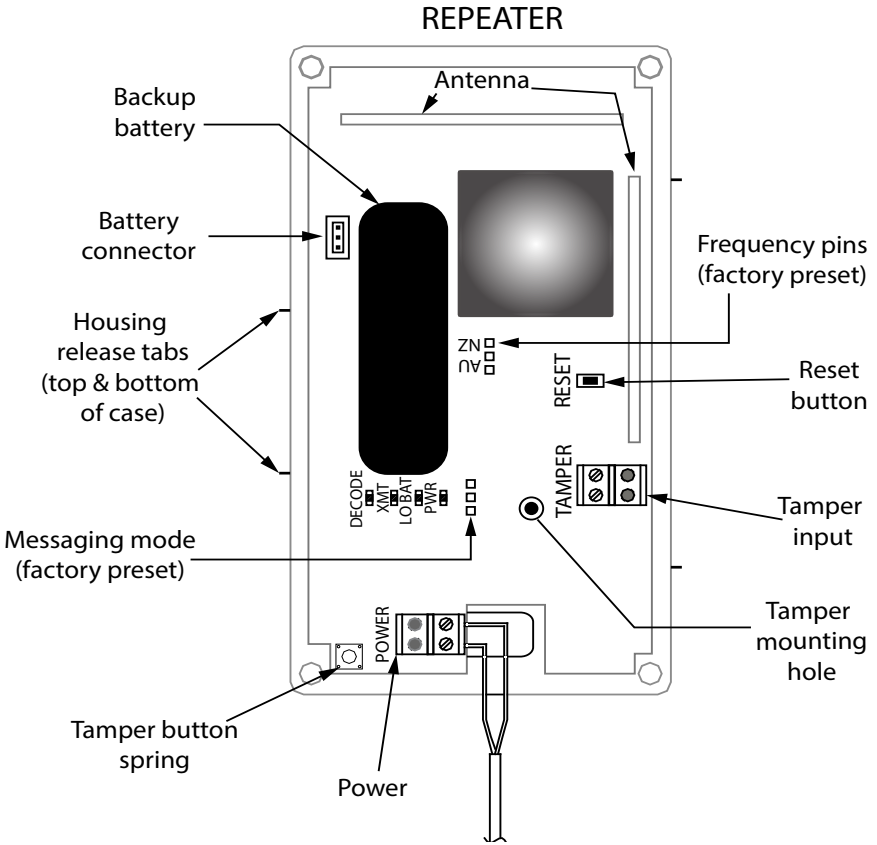

16 Are the wireless repeaters on the site working?

Remove the cover of the repeater box and check the LED indicators on the front of the repeater.

There are five lights on the front of the repeater as shown in "Drawing 21: Repeater LEDs" on page 71.

LED labeled POWER	lit when receiving power. The LED lights GREEN when the unit is receiving power. RED when receiving battery power
LED labeled LO BAT	lit when the high power repeater has a low battery
LED labeled DECODE	flashes when any recognizable RF transmission is received
LED labeled XMT	lit when transmitting an RF transmission

If the POWER light is OFF	check the connection to the power transformer.
----------------------------------	--



Yes – Retest the site for repeater locations



No – Contact PTI Technical Support for further assistance

17 Has there been any construction on, or near, the site?

This includes any changes to the site, adding units, reconfiguring units, changing or adding video surveillance components, changing any electrical wiring, roofing changes, painting, etc. Even with a small change, wiring can be disturbed or disconnected or something new can interfere with equipment operation.

Troubleshooting Door Alarms

The following steps can be used for troubleshooting door alarms. Remember to keep a good set of notes as you troubleshoot. These notes can help for comparison to find problems, prevent confusion, and help speed things up if site service by a technician or telephone technical support are required.

- 1 Determine if the problem with a single door (or alarm input), or with a bank of doors.
- 2 Check the doors in question. Are they loose, possibly moving due to wind or vibration from traffic?
- 3 Check the wireless multiplexer. The circuit boards, cases, and wiring should be checked for obvious damage (i.e., vandalism, burn marks from power surge/lightning, corrosion on the circuit board, water marks, insects, construction debris, etc.).

Problems within unused channels:

- 1 Connect a length of 24 AWG wire from **pin #5** of the power and data terminal block to one of the four screws that mount the circuit board to the metal case.

The metal case of the multiplexer must also be mounted directly to a grounded metal building or tied to a ground rod or grounded metal structural element of the building such as a metal water pipe or ground rod in accordance with local code

- 2 Check that all wire used during the installation meets PTI Security Systems specifications. 18 AWG shielded wire should be used for power and communications.

- 3 Check that there are no breaks in the shield, skinned or bare wire, shorts or breaks in the wire, or splices in the wiring.

In some cases, radio frequency interference (RFI) may also be a problem. All electronic equipment is susceptible to RFI. Radio antennas, military bases, airports, radar, power plants, certain types of lighting, cell phone towers, and communications equipment, are all examples RF generators that can cause interference problems.

PTI's equipment has protection built into it to keep it safe from most RF interference,; however, extreme levels of RF interference can cause communications problems.

Humidity, temperature, and cloud cover, as well as broadcasting strength and proximity to the RF source can contribute to the problem.

As a rule, extreme levels of RF will cause the system data communications to go on and off (data comm on/data comm off) or cause the system to report scattered false door activity.

Warranty & Disclaimer

PTI Security Systems warrants its products and equipment to conform to its own specifications and to be free from defects in materials and workmanship, under normal use and service, for a period of one year from the date of shipment. Within the warranty period, PTI Security Systems will repair or replace, at its option, all or any part of the warranted product which fails due to materials and/or workmanship. PTI Security Systems will not be responsible for the dismantling and/or re-installation charges. To utilize this warranty, the customer must be given a Return Materials Authorization (RMA) number by PTI Security Systems. The customer must pay all shipping costs for returning the product.

This warranty does not apply in cases of improper installation, misuse, failure to follow the installation and operating instructions, alteration, abuse, accident, tampering, natural events (lightning, flooding, storms, etc.), and repair by anyone other than PTI Security Systems.

This warranty is exclusive and in lieu of all other warranties, expressed or implied, including but not limited to the implied warranties of merchantability and fitness for a particular purpose. PTI Security Systems will not be liable to anyone for any consequential or incidental damages for breach of this warranty or any other warranties.

This warranty will not be modified or varied. PTI Security Systems does not authorize any person to act on its behalf to modify or vary this warranty. This warranty applies to PTI Security Systems products only. All other products, accessories, or attachments used in conjunction with our equipment, including batteries, will be covered solely by their own warranty, if any. PTI Security Systems will not be liable for any direct, incidental, or consequential damage or loss whatsoever, caused by the malfunction of product due to products, accessories, or attachments of other manufacturers, including batteries, used in conjunction with our products. This warranty does not cover the replacement of batteries that are used to power PTI Security Systems products.

The customer recognizes that a properly installed and maintained security system may only reduce the risk of events such as burglary, robbery, personal injury, and fire. It does not ensure or guarantee that there will be no death, personal damage, and/or damage to property as a result. PTI Security Systems does not claim that the Product may not be compromised and/or circumvented, or that the Product will prevent any death, personal and/or bodily injury and/or damage to property resulting from burglary, robbery, fire, or otherwise, or that the Product will in all cases provide adequate warning or protection.

PTI Security Systems products should only be installed by qualified installers. The customer is responsible for verifying the qualifications of the selected installer.

PTI Security Systems shall have no liability for any death, injury, or damage, however incurred, based on a claim that PTI Security Systems Products failed to function. However, if PTI Security Systems is held liable, directly or indirectly, for any loss or damage arising under this limited warranty or otherwise, PTI Security Systems's maximum liability will not in any case exceed the purchase price of the Product, which will be fixed as liquidated damages and not as a penalty, and will be the complete and exclusive remedy against PTI Security Systems

Warning: The User should follow all installation, operation, and maintenance instructions. The User is strongly advised to conduct Product and systems test at least once each week. Changes in environmental conditions, electric or electronic disruptions, and tampering may cause the Product to not perform as expected.

Warning: PTI Security Systems warrants its Product to the User. The User is responsible for exercising all due prudence and taking necessary precautions for the safety and protection of lives and property wherever PTI Security Systems Products are installed. PTI Security Systems does not authorize the use of its Products in applications affecting life safety.

Notice. Some PTI Security Systems products use 900Mhz wireless technology. Other devices at the site such as cordless telephones or alarm components may cause interference that will disrupt the operation of the system or may be interfered with by the system. PTI Security Systems assumes no liability for any problems caused by interference. It is the sole responsibility of the user to identify and correct such problems.

PTI SECURITY SYSTEMS



SECURITY



ACCESS



CONTROL



VIDEO

For Technical Support, Please Visit:

tickets.ptisecurity.com